

Supply restoration in power distribution systems – a benchmark for planning under uncertainty

Sylvie Thiébaux¹ and Marie-Odile Cordier²

¹ Computer Sciences Laboratory
The Australian National University
Canberra, ACT 0200, Australia
Sylvie.Thiebaux@anu.edu.au

² IRISA
Campus de Beaulieu
35042 Rennes Cedex, France
Marie-Odile.Cordier@irisa.fr

Abstract. This paper proposes the problem of supply restoration in faulty power distribution systems as a benchmark for planning under uncertainty. This benchmark, which is derived from a significant real-world case, is both simple to understand and easily scalable. The goal is to reconfigure the distribution network to resupply a maximum of consumers affected by the faults. Due to sensor and actuator uncertainty, the location of the faulty areas and the current network configuration are only partially observable. This makes the problem very challenging.

1 Motivation

The use of poor benchmarks for planning under uncertainty has often been pointed out as detrimental to the impact of the field on the wider community. Except for a few testbeds in robot navigation, see e.g. [6], we are still confined to purely artificial problems ranging from escaping the tiger behind the door to making an omelette. While well-understood toy problems are definitely useful in explaining performance differences, it is commonly acknowledged that the danger of such experimentation alone is that it “entices us into solving problems that we understand rather than ones that are interesting” [9].

It is rather paradoxical that the literature on planning under uncertainty features so few benchmarks derived from significant real world cases. After all, the main point of the research line was to better address the necessities of applications, and indeed a lot of realistic problems are modelled quite naturally as partially observable Markov decision processes. If this state of affairs is paradoxical, it is also excusable: planning under uncertainty and in particular partial observability has so far resisted our attempts at building algorithms that scale up, leaving no alternative but experimentation “in the tiny”.

Fortunately, the latest advances in using compact symbolic representations for planning under uncertainty, e.g. [5, 7, 10, 13], hold promise of the situation being about to change. It is likely that the present decade will see fairly generic

planners dealing with problems involving uncertainty on a scale that was far out of reach until now. It is therefore a timely moment to offer concrete challenges to the field by introducing benchmarks that are of practical significance.

This paper describes the problem of restoring supply in a faulty power distribution system, a problem which is of major concern for electricity distributors. It consists in localizing the faulty lines on the distribution network and reconfiguring the network so as to isolate these lines and resupply most consumers. This has to be done within minutes. When reconfiguring, a few parameters such as breakdown costs should ideally be optimised, without violating capacity constraints and overloading parts of the network. More importantly for our purpose, the sensors used to locate the faults and report the current configuration, as well as the actuators used to change configuration, are not always reliable. This leads to missing information about the current state of the network.

In virtue of this accumulation of realistic features, the problem is an ideal testbed for systems claiming to address the necessities of the real-world. One of its advantages compared to other realistic ones is that it is relatively simple to understand. Only a few straightforward classes of components and actions are involved. Further, the topology of power distribution systems makes it easy to scale the problem up or down in order to assess the efficiency of algorithms. However, despite this simplicity, the size of real distribution systems makes them very challenging for methods developed not only in the planning community, but also in related areas, such as model-based diagnosis, repair and reconfiguration.

The paper is organised as follows. Section 2 describes physical characteristics of power distribution systems. Section 3 explains the problem of supply restoration and details the features that makes this problem a challenging and representative testbed. Section 4 gives an overview of the scope of the problem with respect to existing work in the literature, and Section 5 lists the material that will be made available on the benchmark's webpage. Our description of power distribution systems and of the supply restoration problem is based on work done in 1994-1996 in the framework of a contract between IRISA and the French electricity utility Electricité de France (EDF).¹

2 Power Distribution Systems

2.1 Topology

A power distribution system, as in Figure 1, can be viewed as a network of electric lines connected via switching devices (SDs), represented by small squares in the figure, and fed via circuit-breakers (CBs), represented by large squares. Switching devices and circuit-breakers are connected to at most two lines. They have two possible positions: either open or closed. White devices in the figure are open, see e.g. SD61, and the others are closed, see e.g. SD60. A circuit-breaker supplies power iff it is closed, and a switching device stops the power propagation

¹ We thank our collaborators at EDF, in particular Isabelle Delouis-Jacob, Olivier Jehl and Jean-Paul Krivine.

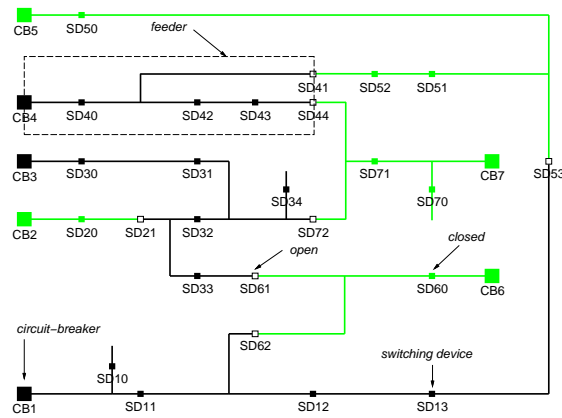

Fig. 1. Power Distribution System (part)

iff it is open. Consumers may be located on any line, and are then only supplied when their line is supplied.

Distribution networks have a meshable structure exploited radially: the positions of the devices are set so that the paths taken by the power of each circuit-breaker form a tree called a feeder. The root of a feeder is a circuit-breaker, and its leaves are whatever switching devices downstream happen to be open at the time. In most cases, each line belongs to one feeder at a time.² For illustration, the boxed area in the figure shows one of the feeders, and adjacent feeders are distinguished using alternately black or grey.

2.2 Faults

Power distribution systems are often subject to permanent³ faults (short circuits) occurring on one or even several lines. Since these short circuits are mainly due to bad weather conditions and lightning, multiple faults are not rare. Upon occurrence of a fault, the circuit-breaker feeding the faulty line opens in order to protect the rest of its feeder from damaging overloads. For instance, if a fault occurs on the line between SD12 and SD13, CB1 will open. As a result, all consumers located on that feeder are left without power. Simply reclosing the circuit-breaker will not help. Since the fault is permanent, the circuit-breaker will still be feeding it and will open again. Instead, using the sensors and actuators described below, the faulty lines must be located and the network reconfigured so as to isolate them and restore the supply to the non-faulty lines. This has to be done within a few minutes.

² In certain circumstances, it is possible for a line to be fed by multiple circuit-breakers, i.e., to belong to more than one feeder. In that case, these circuit-breakers are leaves of each other's feeder.

³ Technically, a permanent fault is one that cannot be eliminated by automatic protection devices such as shunts and reclosers.

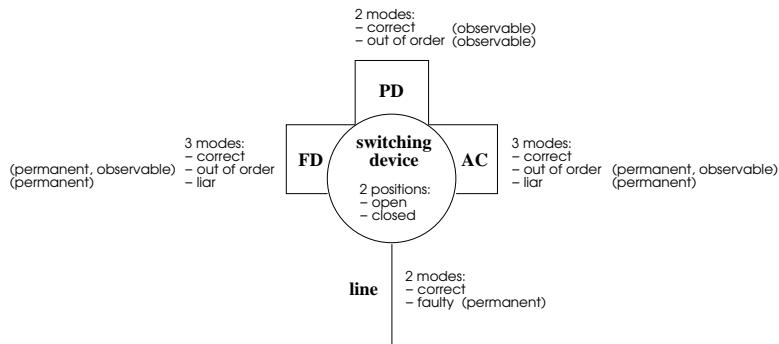

Fig. 2. Possible states and modes of the network components

2.3 Sensors and actuators

As shown in figure 2, switching devices are equipped with a remote-controlled actuator (AC) used to change their position, a position detector (PD) sensing this position, and a fault detector (FD) sensing the presence of faults. Circuit-breakers are only equipped with the former two.

In normal operation, fault detectors work as follows. As long as a switching device is fed, its fault detector constantly indicates whether or not it has “seen a fault pass” i.e., whether or not a fault is downstream of the device on the feeder.⁴ If the device is not fed, its fault detector retains the status it had when last fed. For instance, if the line between SD12 and SD13 is faulty, SD11 and SD12 should indicate a fault while the other devices on this feeder should not. Then CB1 should open and the fault detectors’ information should remain the same until they are fed again. So, normally, a fault is located on the line between a sequence of switching devices whose fault detectors indicate that it is downstream and a sequence of switching devices whose fault detectors indicate that it is not.

Note that in the case of multiple faults on the same feeder, only the most downstream faults will be detected. A more significant problem is that fault detectors are not always correct and can be in one of the following two permanent abnormal modes. In “out of order” mode, they do not provide any information. Obviously, this mode is observable. In “liar” mode, they always lie, i.e. indicate the negation of the correct reading. That mode cannot be directly observed. Due to these abnormalities, the fault location cannot be identified with certainty on the sole basis of the information returned by the fault detectors.

The primary role of actuators is to open switching devices so as to isolate suspected lines and close others to direct the power from other feeders towards the non-faulty lines. In fact, opening and closing devices are the only available actions in our problem. In normal mode, an actuator executes the requested switching operation and returns a positive notification. Actuators are not always

⁴ In the rare event when a switching device belongs to multiple feeders, it indicates a fault if there is one downstream with respect to at least one of the feeders.

reliable and can be in one of the following permanent abnormal modes: “out of order”, i.e. the actuator fails to execute the operation and sends a negative notification, or “liar”, i.e. it fails to execute the operation but sends a positive notification. The former mode is observable while the latter is generally not.

The continuous information provided by the position detectors often removes uncertainty about the success of switching operations positively notified by actuators. However, position detectors too can be “out of order”. In that mode, they do not return any information for an indeterminate time, during which, even though the mode is observable, the network configuration remains uncertain. Figure 2 summarizes the various modes of the network components.

2.4 Size

Like many European power distribution systems, EDF networks are composed of some hundreds of feeders (typically from 100 to 300), each of which contains a few remote-controlled switching devices (the objective is to equip each feeder with 2-3 of them). A feeder has only a very few neighbours (typically from 1 to 4), and as will be seen below, essentially only those will play a role in supply restoration. Hence reasoning is very local, and the network in figure 1 is a good representative of the complexity of the real problem. The problem can trivially be scaled up or down by modifying the number of switching devices per feeder and the number of neighbours of feeders. For experimentation purposes, it should be easy to generate random variations of existing networks.

3 The problem

3.1 Supply restoration

The problem of supply restoration is that of reconfiguring the network in order to resupply the consumers following the loss of one or more feeders. It amounts to building a restoration plan consisting of opening/closing operations. This plan should isolate the faulty lines by prescribing to open the switching devices surrounding them. It should also restore supply to the non-faulty areas of the lost feeders by prescribing to operate devices so as to direct the power towards these areas. Note that although we use the term restoration *plan*, there is no constraint on the nature of the plan (linear, conditional, etc ...) nor a requirement to commit in advance to more than the next action to execute.

The following capacity constraint determines which restoration plans are admissible: at any time, circuit-breakers and lines can only support a certain maximal power. This might prevent directing the power through certain paths and resupplying all the non-faulty areas. In this paper, we will add another constraint which is not present in the original problem but will considerably reduce the search space: we only consider plans which extend existing feeders. That is, the plan should not transfer any of the load that a healthy feeder had at the time of the incident to another feeder. Other types of plans are very rarely used in practice because they require a complex protocol with the dispatching center.

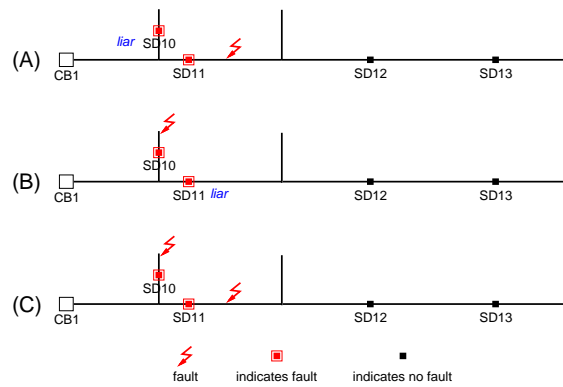

Fig. 3. Three likely hypotheses

A good plan will optimize certain parameters under these constraints. Naturally, breakdown costs should be minimised, i.e., as much load as possible should be resupplied as fast as possible, with priority being given to critical consumers like hospitals. Ideally the number of switching operations should also be optimised, so as to stay close to the configuration in which the network is normally exploited (called the normal configuration), and power margins of circuit-breakers should be balanced in anticipation of the next load peak.

Obviously, the identification of the faulty lines is crucial to the success of the restoration. However, as explained above, this cannot be done on the basis of the information provided by the fault detectors alone. Even in the single fault case, several hypotheses of fault location exist, each of which corresponds to an hypothesis concerning the behaviour mode (“correct”, “liar”) of the fault detectors. There exist preferences between hypotheses: the probability of multiple faults is much smaller than that of a fault detector lying, and this latter probability is higher when the fault detector indicates a fault downstream than when it does not because fault detectors do not detect all types of faults. But in fact, only reconfiguration actions may enable us to gather enough information to discriminate, as illustrated in the example below.

3.2 Example

Taking our example network, suppose that CB1 opens, leaving the bottom-most feeder on the figure unsupplied. Suppose further that the fault detectors of SD10 and SD11 indicate a fault downstream, while the other fault detectors do not. Among the most probable diagnoses are those shown in Figure 3: (A) the fault detector of SD10 lies and there is only one fault, located between SD11 and SD12, (B) the fault detector of SD11 lies and there is only one fault, downstream of SD10, and (C) none of the fault detectors lie and there are two faults.

Assuming that we consider (A) to be the most likely, a promising restoration plan goes as follows: isolate the line between SD11 and SD12 by opening these devices, resupply the lines upstream of the fault by reclosing CB1, and have CB5 resupply the downstream lines by closing SD53.

Suppose the execution of the plan proceeds correctly up to the point where CB1 reopens when we attempt to close it. Either this is due to a wrong fault location hypothesis (e.g., (B) or (C) was the case), or to a fault which could not be detected (here, a fault between CB1 and SD11), or to a failure of an operation meant to isolate the fault (the actuator of SD11 could be lying, and if its position detector is out of order, this cannot be directly detected). Since faults can in principle occur at anytime, it could even be the case that a new fault has appeared while we were attempting to restore the supply. However, to keep this benchmark manageable, we will assume that no new fault can occur during power restoration.

We let the reader elaborate on what are good choices for the next action to perform. If we choose to open SD10 and reclose CB1 and it works, this tends to favour hypothesis (B). In any case, this eliminates the possibility of a fault between CB1 and SD11, as well as the possibility of the actuator of SD11 lying in the context of hypotheses (A) or (C). If on the other hand CB1 opens again, we have to look further. Alternatively, we could also choose to test hypothesis (B) by closing SD62 and see whether CB6 opens, but this could be costly as this could lead to the temporary loss of a new feeder. Or perhaps we should close SD53 as in the original plan ... Complete examples will be found in the benchmark's website.

3.3 Main features of the problem

Three main features make this problem particularly interesting for state of the art planners. Firstly, partial observability is a crucial issue. Executing reconfiguration actions is necessary not only to change the state of the system, but also to gain vital information. Conversely, a good knowledge of the system's state is necessary to choose purposeful actions and avoid increasing breakdown costs. Unlike certain other problems involving partial observability, this one does not even offer the possibility of gaining information without taking intrusive actions and confronting the resulting observations with the expected ones. In sum, the problem is very representative of the need to trade off the gain of information which results from sensing and acting, the expected reward/penalty resulting from performing the right/wrong actions, and the cost of failing to act quickly. This is an optimisation problem, rather than one of merely reaching a desired state.

Secondly, the size of the state space and the structure of the problem make complete state enumeration – and a fortiori the incremental construction of a universal plan – absolutely impractical. At the same time, if plan utility is something to worry about, care should be exercised in pruning unlikely states in a belief state, as getting rid of an unlikely but potentially very costly state will spoil utility evaluation. Therefore, algorithms working with compact domain representations or using very effective domain control knowledge are necessary. Concerning designing appropriate control knowledge, a challenging aspect of the benchmark is that it is still an open problem: functions estimating the utility of network configurations exist, but the optimal solutions or rules of thumb for the

selection of actions with high utility are unknown. In fact, even discovering of how best to order given switching operations would be useful.

Finally, as in other planning benchmarks derived from real-world applications, see e.g., [11], actions have effects which are quite complex to model. For instance, closing a device increases the load of a circuit-breaker which should have the capacity to produce the additional resource. Closing a device may also lead to a fault being fed by the circuit-breaker, which will then open, leaving the lines on its feeder unsupplied. All this requires formalisms and planners which can handle domain constraints, infer ramifications and reason about resources, or at least enable the specification of elaborate context-dependent effects in the action descriptions.

4 Position of the problem in the literature

Supply restoration is not only very representative of issues that need to be addressed when dealing with real-world applications, but also of current research trends in planning and related areas. We now position the problem with respect to the literature, identify approaches which look likely to lead to advances in this domain, and describe existing work on this problem.

4.1 Planning and related areas

Progressive planners, such as TLplan [1] and TALplanner [12], appear as promising candidates to get somewhere with this benchmark in the very near future. PTLplan [10] is an extension of TLplan to deal with partial observability, stochastic actions, and probabilistic planning. Two features make progressive planners particularly interesting for the problem: the expressiveness of the planning language, and the extensive use of domain-control knowledge. After research effort is invested in understanding additional requirements placed by planning under uncertainty when it comes to the specification of domain control knowledge, these generic planners should be able to mimic strategies used by the domain specific supply restoration systems described below.

This said, progressive planners do not seem very-well equipped to deal with the full scope of the problem, and in particular with discovering plans with high utility. Firstly, there is no built-in capabilities for optimisation in TLplan yet. Secondly, because they perform explicit state enumeration, these planners are better suited to produce plans according to a domain-specific strategy, than to perform extensive search for optimal plans.

Recent planners working with much more compact domain representations include very expressive ones like Zander [13], which is based on stochastic satisfiability, and MBP [7], which is based on model-checking. At present, MBP generates plans that are guaranteed to achieve the goal despite sensor and actuator uncertainty. This is impractical for our benchmark where uncertainty just creates too many cases to be handled, and where gaining information up to the

point of being 100% sure to have reached a desired state often incurs unacceptable breakdown costs. Extensions to MBP which would relax this requirement would have a strong potential for excellent results on our problem.

In the longer term, the answer to the question of the production of high quality plans may well come from planners based on decision-theoretic regression [4]. First-order decision-theoretic regression is the key to symbolic dynamic programming, and does not require state or even action enumeration. It has been integrated with the situation calculus, leading to a very powerful problem-solving framework [5]. At present, this framework only deals with fully observable Markov decision processes, but once extensions to the partially observable case are available, our benchmark should be near-perfect to evaluate their benefits.

Another worthwhile direction would be to investigate the appropriateness for our problem of the general-purpose POMDP heuristics given in [6, 3].

Supply restoration is also typical of problems of interests in other areas such as model-based diagnosis, repair, reconfiguration, and execution, see e.g. [8, 15, 18]. The approaches in this area are often rely on a two level architecture featuring a diagnostic reasoner and a quasi-classical planner. If systems based on these approaches have so far been the most effective in dealing with similar application contexts, they still have some limits when confronted with our problem: they assume that all relevant information can be reliably acquired when needed, and that actions are reliable and sometimes elementary (a typical case is component replacements). Moreover, they are often applied to problems with belief states small enough for their content to be easily enumerated. These limits are largely due to the use of now obsolete planners which are unable to operate under uncertainty or to model actions with complex effects. Recent work on planning under uncertainty could be used in the framework of these approaches to remedy some of their current drawbacks.

A further line of research worth mentioning here is the modelling of diagnostic problem solving, including observations, actions, exogenous events, and diagnosis/repair/reconfiguration plans, in languages close to those used in planning, e.g. the situation calculus [14] or narratives [2]. It would be of interest to encode our example in these languages and experiment with the related planning technology [5, 12].

4.2 Existing work on the problem and related ones

Other works of interest are those concerned with similar AI applications to power systems. Space precludes more than the mention a few of them here.

SyDRe [16] is a simple decision-theoretic prototype for supply restoration on power distribution systems. It operates successfully in presence of an arbitrary number of faults, sensor and actuator uncertainties. However it does not reason on how to gain information: it generates a sequence of actions for the most probable state hypothesis, starts its execution, and revises this plan whenever the history of actions/observations shows that another hypothesis is more probable.

Diagnosis and supply restoration in power *transmission* systems has been studied e.g. in [8]. A crucial difference with our proposed testbed is that ob-

servations and actions are assumed to be reliable, which is reasonable when considering transmission systems. Sensor and actuator uncertainty make power distribution systems much more challenging.

The model-based reactive planner Burton has been applied to spacecraft engine reconfiguration [18]. Although this reconfiguration problem seems easier to handle – in particular observations and actions are reliable – it shares many aspects with the present benchmark. Indeed power distribution systems are another representative of the sensor rich, embedded, reconfigurable systems, which Williams and Nayak have dubbed *immobots* [17]. A number of choices made in Burton and SyDRe are similar. For instance the “upstream progression heuristic” is used in both, and they both sacrifice optimality for the sake of efficiency, by generating a sequence of actions for the most probable hypothesis and revising the plan if necessary.

The above systems can be used as a reference to measure the performance in time and solution quality of today’s generic uncertainty planners. Ideally, we would like to see generic planners achieving comparable time performance by using extensive domain-control knowledge, as well as planners producing plans of much higher quality by reasoning on how to gain information.

5 Web site for this benchmark

We plan to make the items listed below available by early 2002 on the benchmark’s web site <http://csl.anu.edu.au/~thieboux/benchmarks/pds/>.

Formal description of the problem. For various reasons, the choice made in this paper is to provide a textual description of the problem rather than a formal one. We believe that this description is precise enough to be effectively usable. However, the web site will provide an extended version of the paper including a formal description in a TLplan-like language.

Network data and problem generator. Confidentiality issues prevent us to release data concerning existing EDF power distribution systems. However, we will make artificial data used in SyDRe’s test suite available, including sample problems and suboptimal solutions produced by SyDRe. We also plan to provide a random network/problem generator for systematic experiments.

Simulator and supply restoration system. The Standard ML implementation of SyDRe will be downloadable from the web site. It includes a network simulator which can be used as a predictive model and a supply restoration component which can serve as a reference basis for comparative tests. However, since SyDRe employs a very myopic strategy which does not reason about how to reduce uncertainty, the ultimate goal is to obtain better quality plans than those produced by SyDRe.

6 Conclusion

This paper proposes the use of supply restoration in power distribution systems as a benchmark for planning under uncertainty. The time has come to mea-

sure planning systems against such realistic examples to complement the deeper analyses obtained with well-understood artificial problems. We have identified approaches which are likely candidates for progress with this benchmark, as well as their current limits. We hope that this paper will motivate the planning community to tackle the problem, and that the present decade will see success with at least a scaled down version of the above network example.

References

1. F. Bacchus and F. Kabanza. Using temporal logic to express search control knowledge for planning. *Artificial Intelligence*, 116(1-2), 2000.
2. C. Baral, S. McIlraith, and T. Son. Formulating diagnostic problem solving using an action language with narratives and sensing. In *Proc. KR*, 2000.
3. B. Bonet and H. Geffner. Planning with incomplete information as heuristic search in belief space. In *Proc. AIPS*, pages 52–61, 2000.
4. C. Boutilier, R. Dearden, and M. Goldszmidt. Stochastic dynamic programming with factored representations. *Artificial Intelligence*, 121(1-2):49–107, 2000.
5. C. Boutilier, R. Reiter, and B. Price. Symbolic dynamic programming for first-order MDPs. In *Proc. IJCAI*, 2001.
6. A.R. Cassandra, L. Kaelbling, and J.A. Kurien. Acting under Uncertainty: Discrete Bayesian Models for Mobile-Robot Navigation. In *Proc. IROS-96*, 1996.
7. A. Cimatti, M. Roveri, and P. Traverso. Planning in nondeterministic domains under partial observability. In *Proc. IJCAI*, 2001.
8. G. Friedrich and W. Nejdl. Choosing observations and actions in model-based diagnosis-repair systems. In *Proc. KR*, pages 489–498, 1992.
9. S. Hanks, M.E. Pollack, and P.R. Cohen. Benchmarks, testbeds, controlled experimentation, and the design of agent architectures. *AI Magazine*, 4(14):17–42, 1993.
10. L. Karlsson. Conditional progressive planning under uncertainty. In *Proc. IJCAI*, 2001.
11. J. Koehler and K. Schuster. Elevator control as a planning problem. In *Proc. AIPS*, pages 331–338, 2000.
12. J. Kvarnström, P. Doherty, and P. Haslum. Extending TALplanner with concurrency and resources. In *Proc. ECAI*, pages 501–505, 2000.
13. S.M. Majercik and M.L. Littman. Contingent planning under uncertainty via stochastic satisfiability. In *Proc. AAAI*, pages 549–556, 1999.
14. S. McIlraith. Explanatory diagnosis: conjecturing actions to explain observations. In *Proc. KR*, pages 167–177, 1998.
15. Y. Sun and D. Weld. Beyond simple observation: Planning to diagnose. In *Proc. AAAI*, pages 182–187, 1993.
16. S. Thiébaux, M.-O. Cordier, O. Jehl, and J.-P. Krivine. Supply restoration in power distribution systems — a case study in integrating model-based diagnosis and repair planning. In *Proc. UAI*, pages 525–532, 1996.
17. B. Williams and P. Nayak. Immobile robots – AI in the new millennium. *AI Magazine*, 17(3), 1996.
18. B. Williams and P. Nayak. A reactive planner for a model-based executive. In *Proc. IJCAI*, pages 1178–1185, 1997.